

chandler  **WORLD
FAMOUS**

**MODEL
CM491**

BUTTON SEWING MACHINE



**PARTS
BOOK**

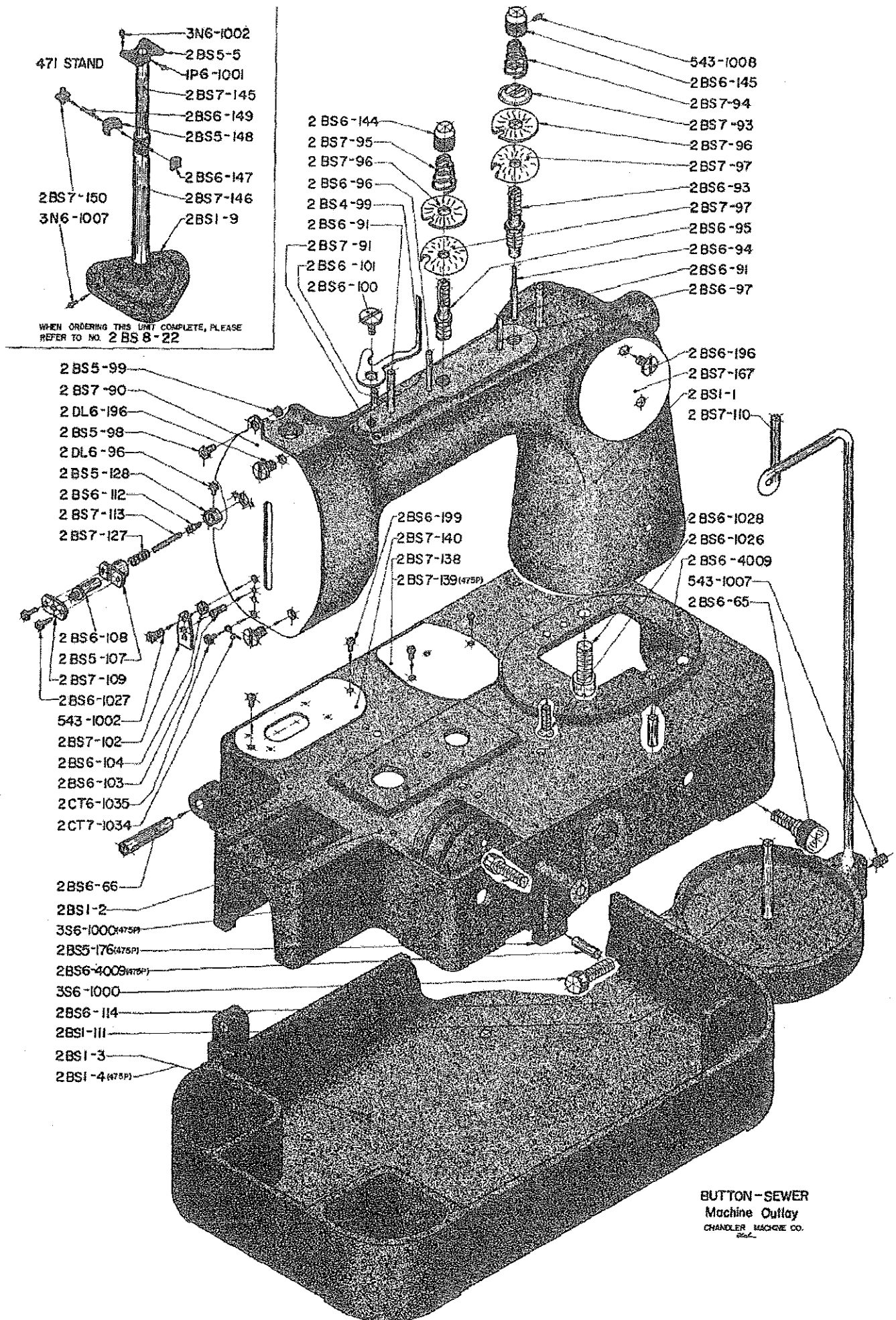

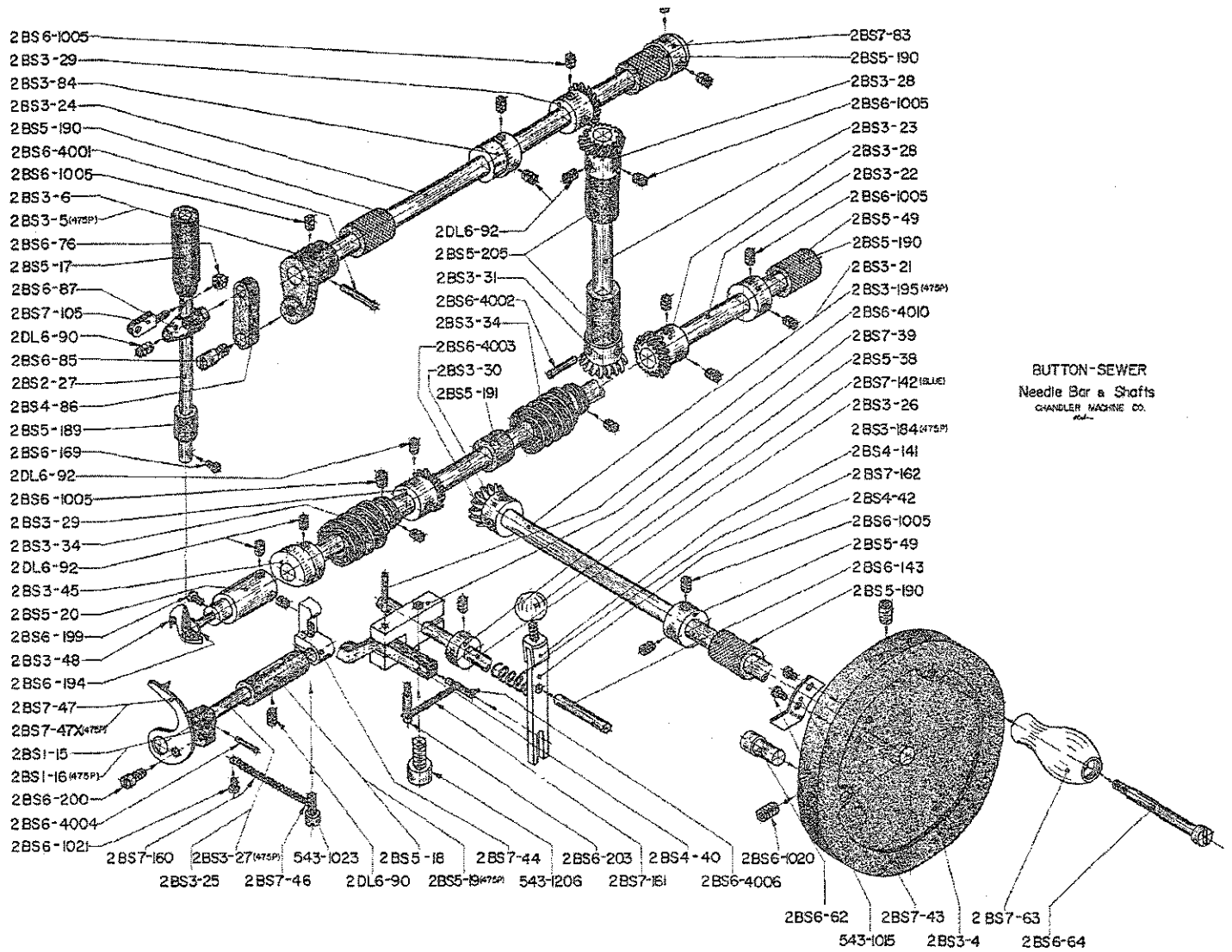

HAND-BUTTON-SEWER
471 Linkage
CHANDLER MACHINE CO.
M.A.

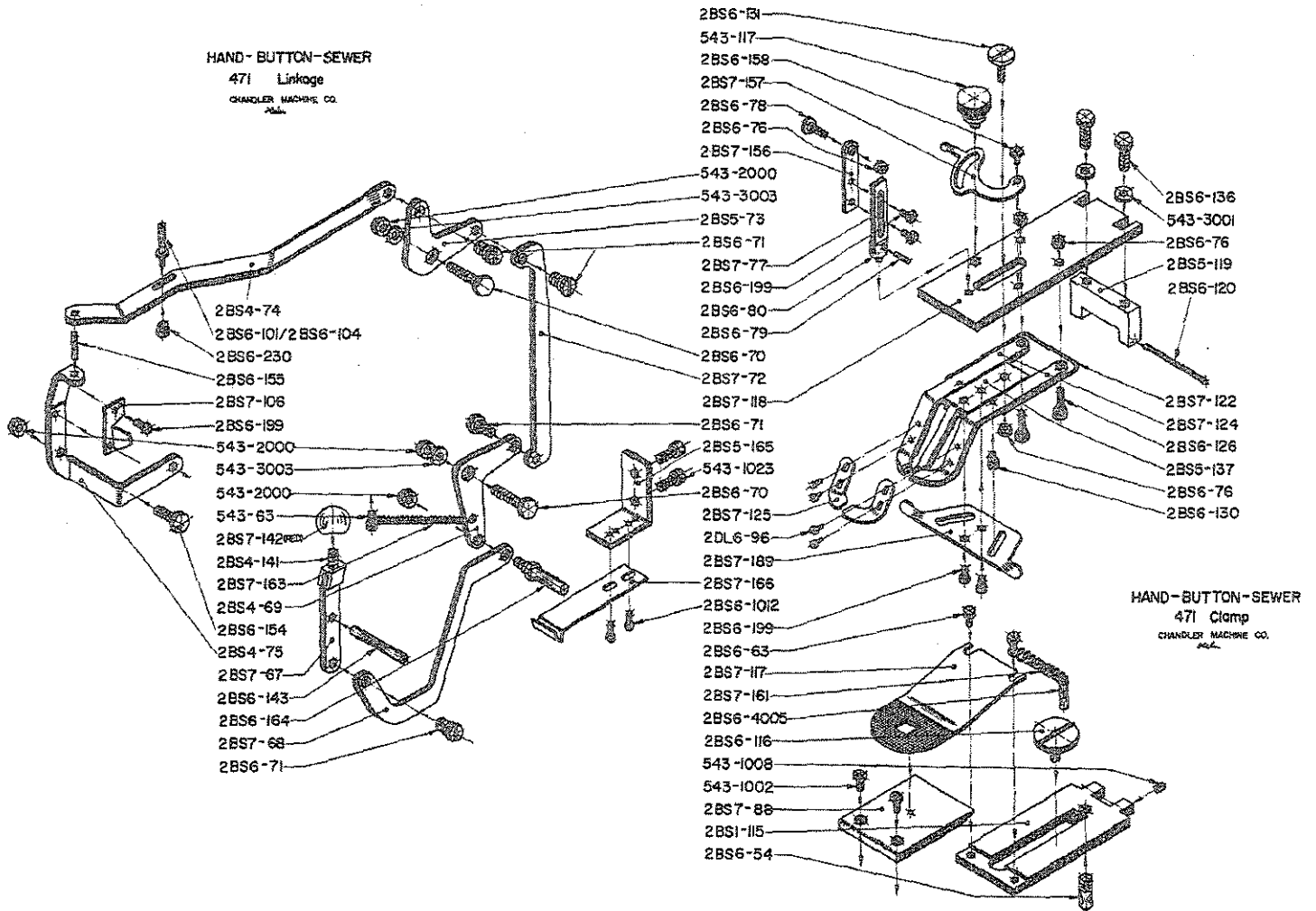

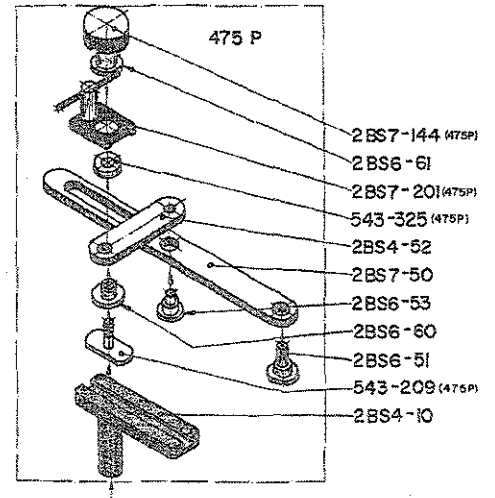
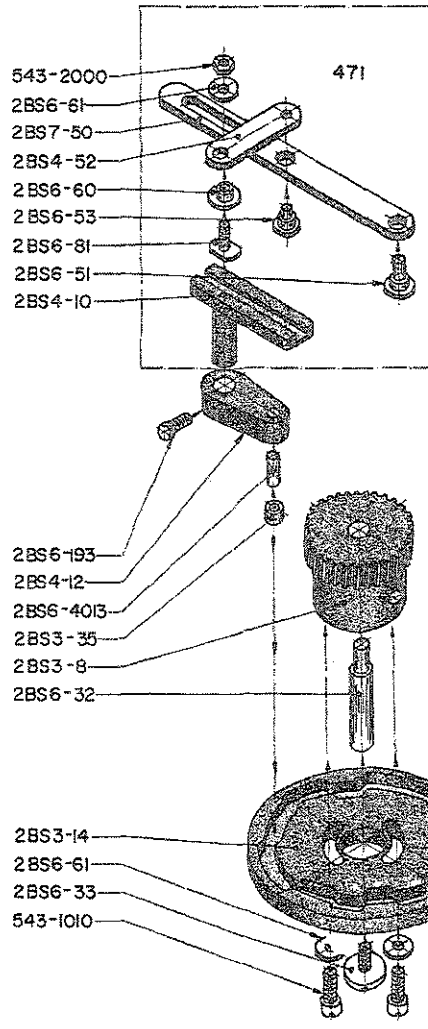
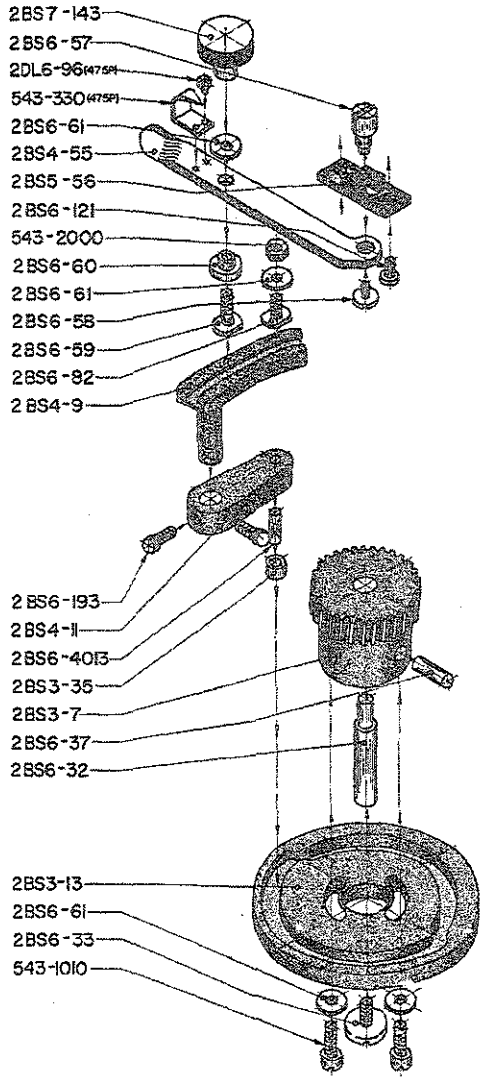

BUTTON SEWER
 Gears & Cams
 CHANDLER MACHINE CO.
 1926

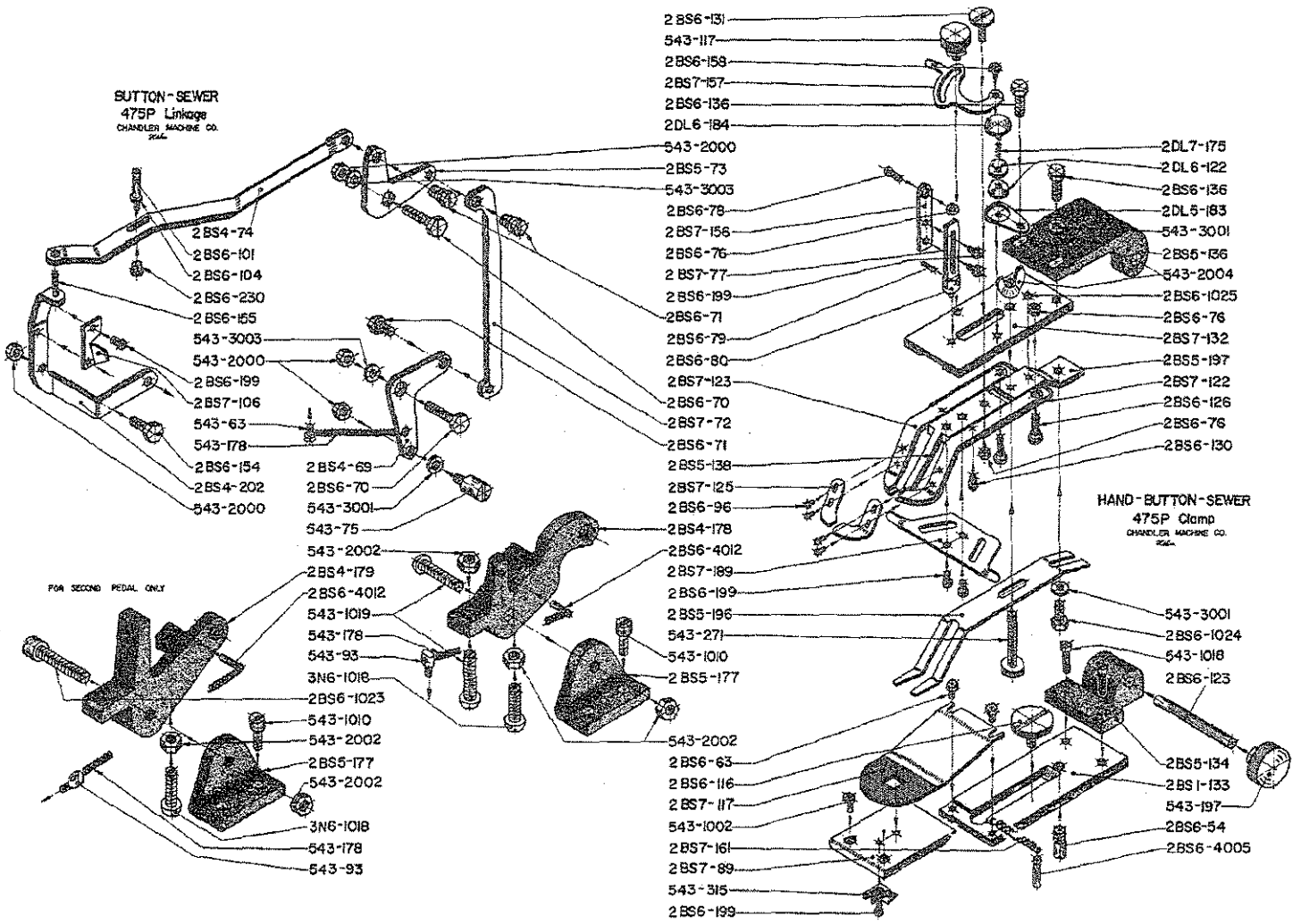

HAND-BUTTON-SEWER
 475 P CLUTCH
 CHANDLER MACHINE CO.

WHEN ORDERING THIS UNIT COMPLETE,
 PLEASE REFER TO NO. 2 BS8-23

THE FOLLOWING PARTS WILL NOT BE

- INCLUDED: 2 BS 3 - 185
 2 BS 5 - 49
 2 BS 5 - 190
 2 BS 6 - 1005
 2 BS 6 - 1029
 2 BS 9 - 210

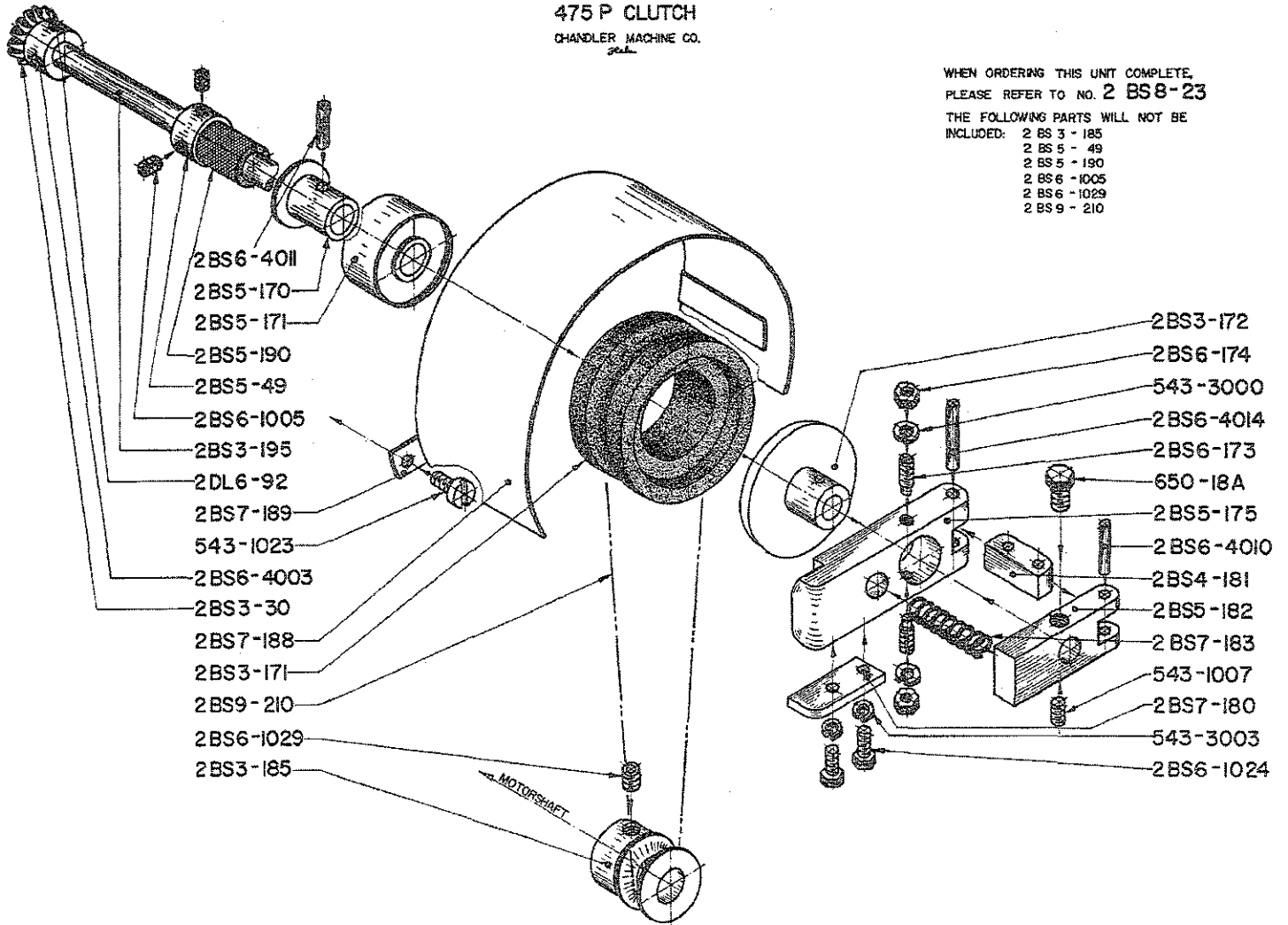

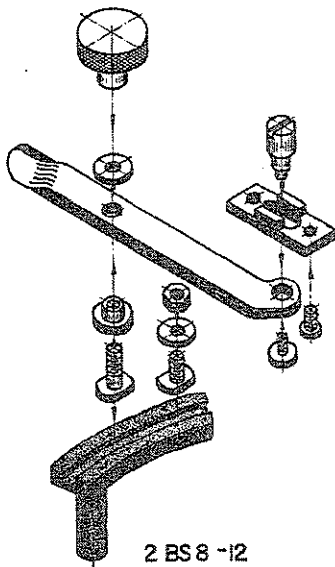

2 BS8-12

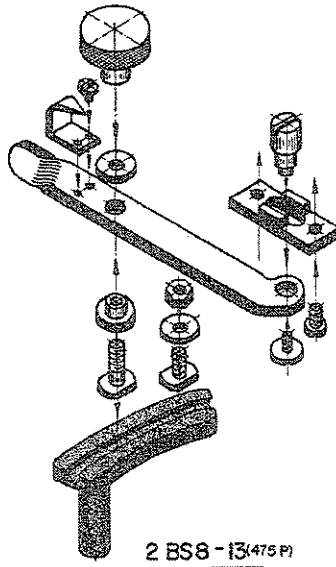

2 BS8-13 (475P)

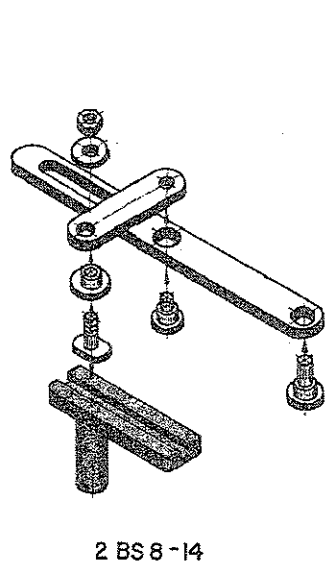

2 BS8-14

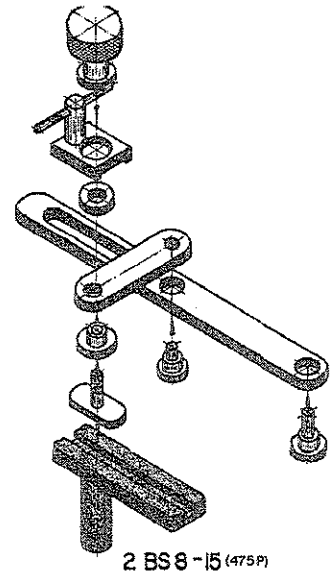

2 BS8-15 (475P)

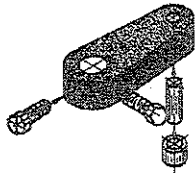

2 BS8-16

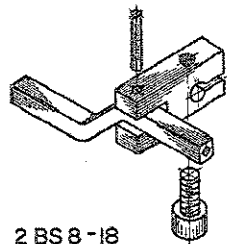

2 BS8-18

HAND - BUTTON - SEWER
CHANDLER MACHINE CO.
made in U.S.A.

WHEN ORDERING ANY
OF THESE UNITS
COMPLETE, REFER
TO NUMBER ON
THIS PAGE ONLY.

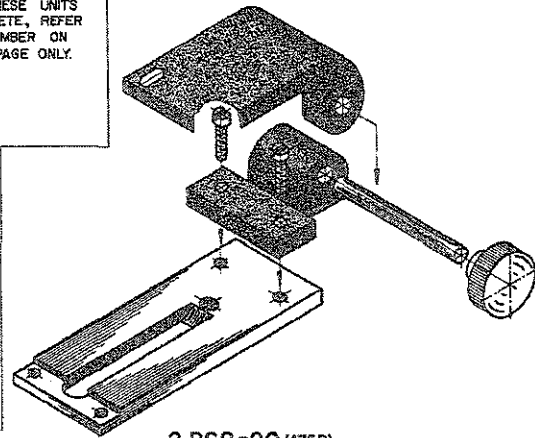

2 BS8-20 (475P)

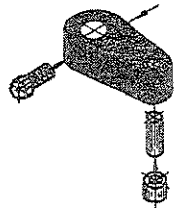

2 BS8-17

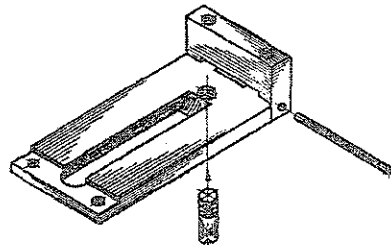

2 BS8-19



2 BS8-21
(475P)

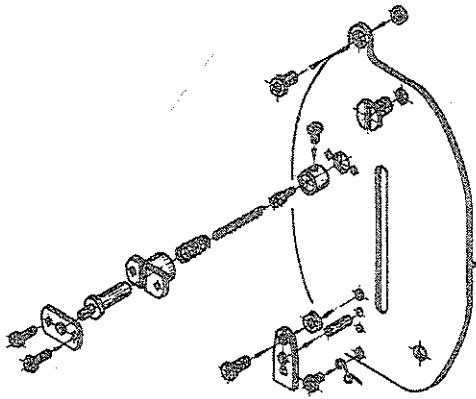

2 BS 8 - 1

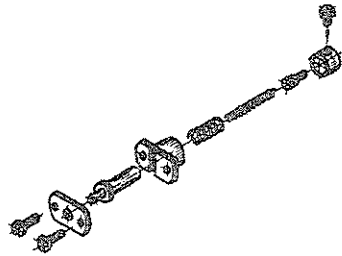

2 BS 8 - 2

BUTTON - SEWER
CHANDLER MACHINE CO.
202

WHEN ORDERING ANY OF THESE UNITS
COMPLETE, REFER TO NUMBER ON THIS
PAGE ONLY.



2 BS 8 - 3



2 BS 8 - 4

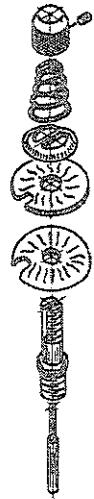

2 BS 8 - 5

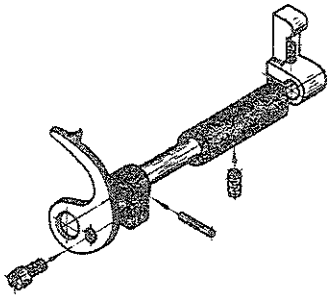

2 BS 8 - 6

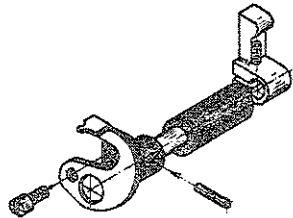

2 BS 8 - 7 (475 P)

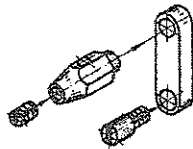

2 BS 8 - 8

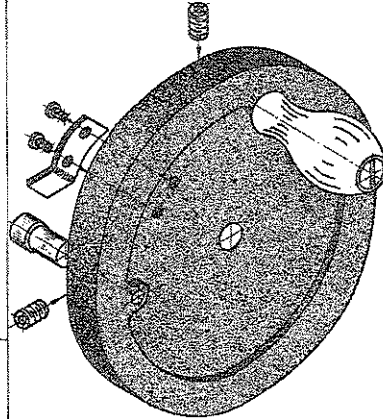

2 BS 8 - 9



2 BS 8 - 10



2 BS 8 - 11

HAND BUTTON SEWER 475 P

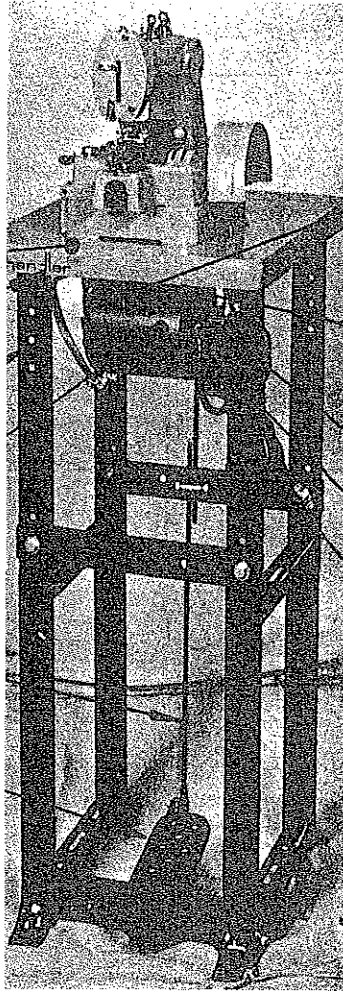

Please note:
Chandler Models 401, 461, 471, 481,
472, 475P & 485P are also represented in this book.

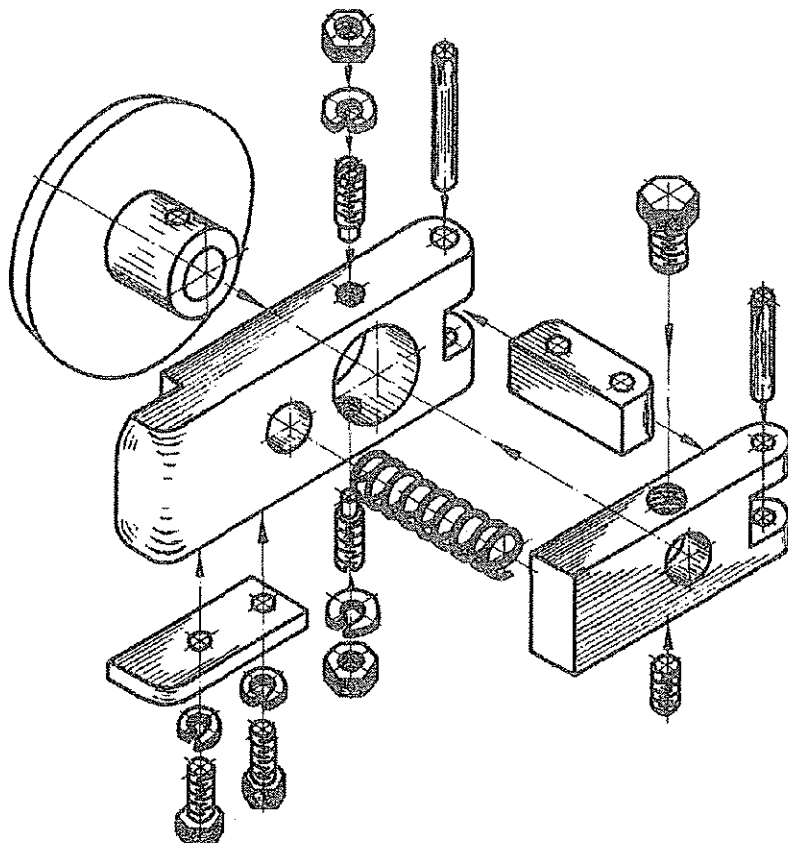

2 BS 8-24 (475P)

WHEN ORDERING ANY OF THESE UNITS COMPLETE, REFER TO NUMBER ON THIS PAGE ONLY.

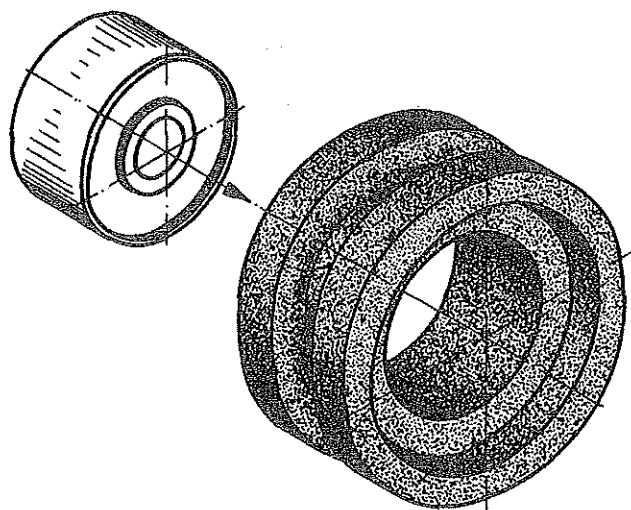

2 BS 8-25 (475P)

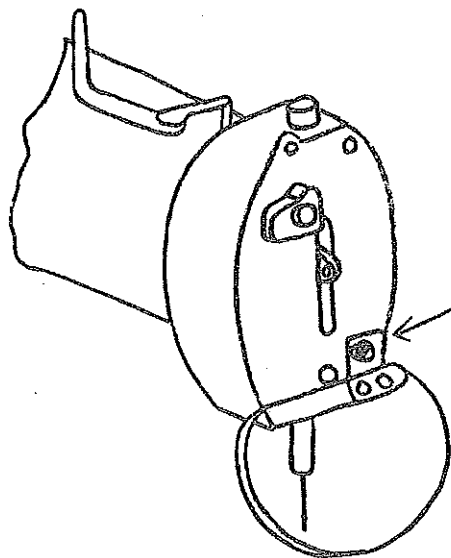

USE THIS SCREW TO ATTACH
COMBINATION FINGER AND
EYE GUARD.

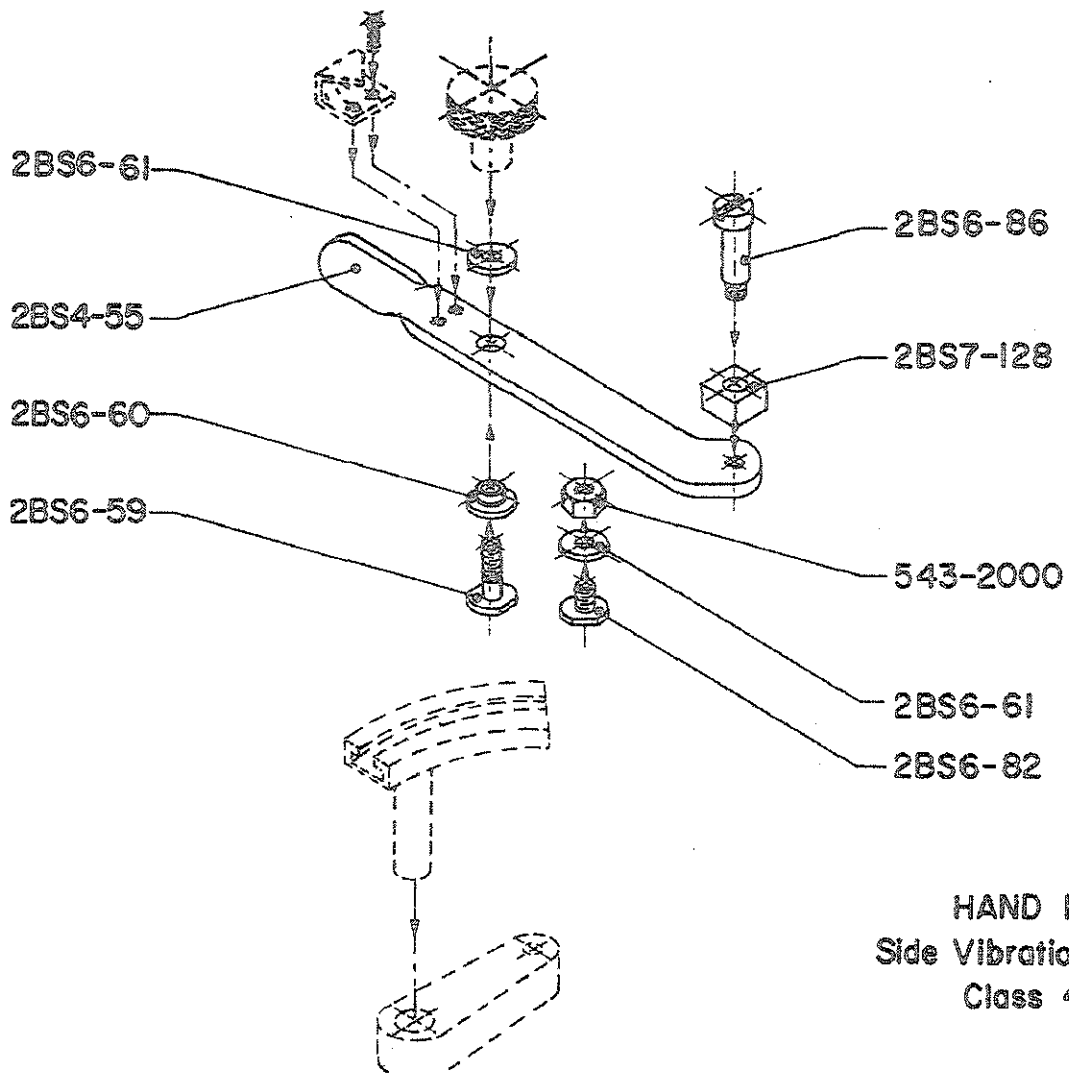

HAND BUTTON SEWER
Side Vibration Mechanism Revision
Class 48I and 485-P

INSTRUCTIONS FOR INSTALLING CLUTCH UNIT ON

472 & 475P & 485P

Refer to parts book re: part numbers

With needle bar in highest or stop position, and stop shaft 2BS3-184 protruding approximately 3/8", the clutch assembly is positioned on clutch shaft 2BS3-195 so that the stop shaft is relieving tension from the clutch, allowing pulley to spin freely. Cap screw will be tightened on flat of shaft and Allen screw on bottom is also tightened. With power off, run the machine thru one cycle by hand. When stop shaft is activated, part No. 2BS-7180, stop blade, should be under leading end of stop shaft, the needle bar should be in its highest position, and the pulley should be free of the clutch, with a minimal amount of clearance. Any adjustments for this should be made by moving stop shaft in or out which is governed by the collar inside the machine. With the machine running, the stop blade should be clearing the stop shaft by approximately 1/32 of an inch.

chandler®

The logo consists of two overlapping circles, each containing a stylized map of the world. The words "WORLD" and "FAMOUS" are printed across the top and bottom of the circles, respectively.

MAIN office

131 W. 25th Street
New York, NY 10001
Tel: 212-741-7788
Fax: 212-741-7787

Miami, FL

4013 N.W. 79th Avenue
Miami, FL 33166
Tel: 305-471-0200
Fax: 305-471-0243

Los Angeles, CA

2320 South Hill Street
Los Angeles, CA 90007
Tel: 213-745-8844
Fax: 213-745-8855

CONSEW[®]
CONSOLIDATED SEWING MACHINE CORP.

MODEL

DCS-S3

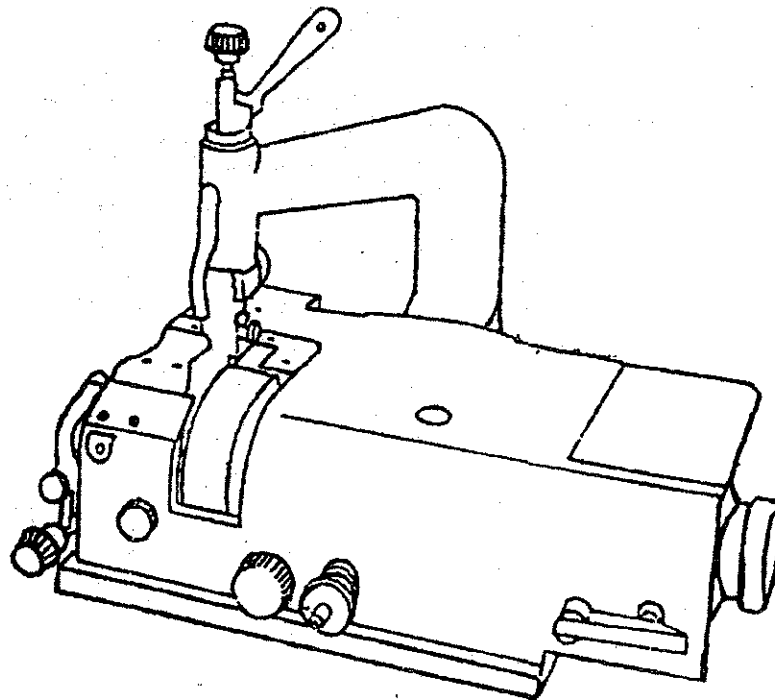

LEATHER SKIVING MACHINE

PARTS BOOK

1. PRESSER FOOT AND OUTER ATTACHMENTS

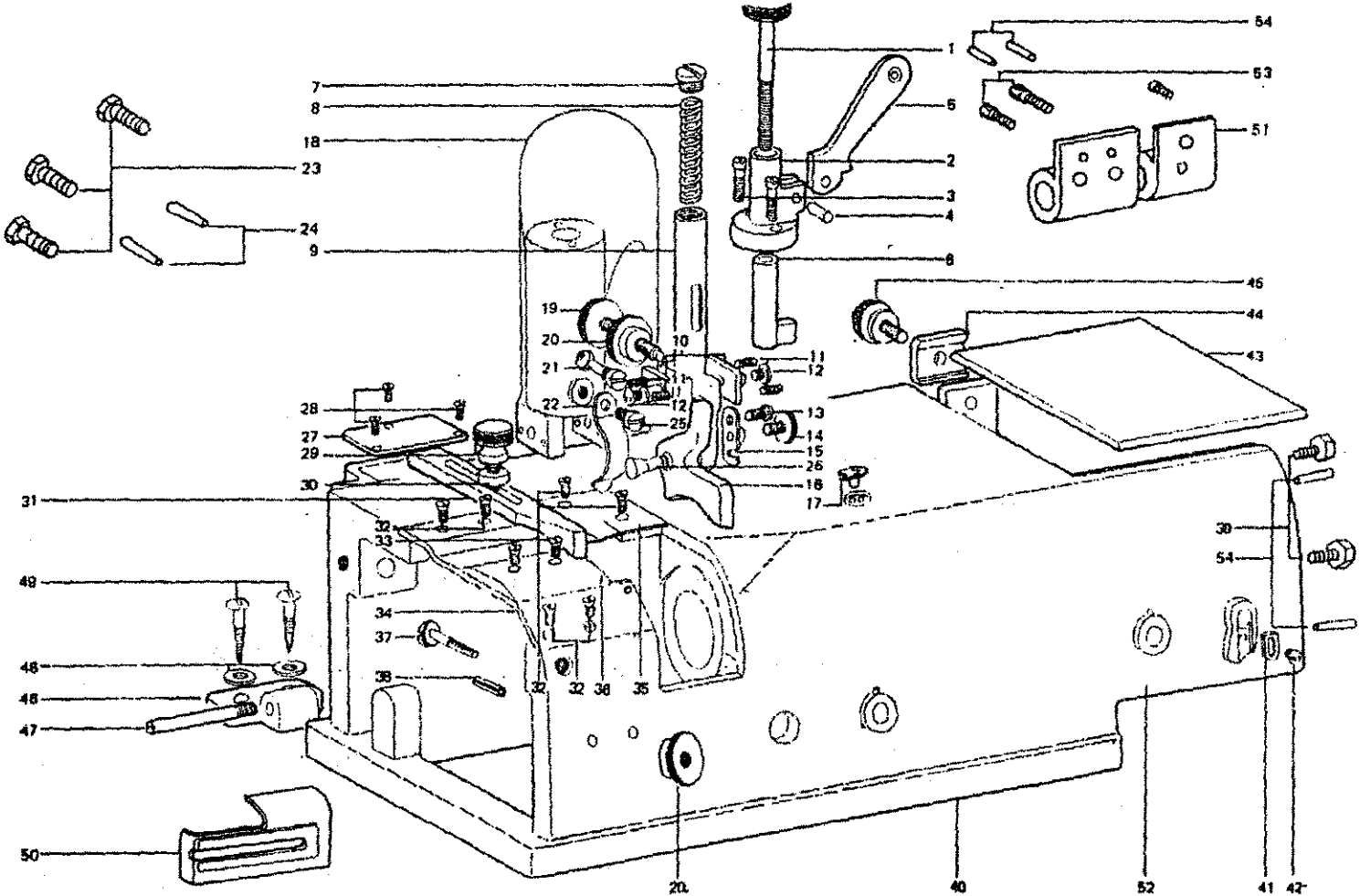

Item No.	Part No.	Description
1-1	1157	Presser bar adjusting screw
1-2	1156	Presser bar lifter bracket (2)
1-3	28156	Presser bar lifter bracket screws (2)
1-4	1316	Presser bar lifter pin
1-5	1153	Presser lifter
1-6	1155	Presser bar lifter lever
1-7	1150	Presser bar cover screw
1-8	1151	Presser bar spring
1-9	1145	Presser bar
1-10	1004	Presser foot slide plates (2)
1-11	11/64	Presser foot slide plate screws (4)
1-12	31628	Presser foot slide plate screw
1-13	31628-10	Presser foot shaft hook metal hinge screw
1-14	1144	Presser foot shaft hook metal set screw
1-15	1132	Presser foot shaft shook metal screw
1-16	1140	Presser loot 50 mm
1-17	1007	Oil cap
1-18	1001	Arm
1-19	1085	Presser foot adjusting screw
1-20	1086	Presser foot adjustable screw nuts (2)
1-21	1152	Presser bar spring pin
1-22	1140	Presser foot spring
1-23	1625	Inner hex head screw
1-24	1628	Taper pin
1-25	3163	Presser foot spring screw
1-26	1141	Presser foot shaft
1-27	1122	Worm chamber plate
1-28	9634	Flat screw
1-29	1009	Ruler set screw
1-30	1008	Ruler set screw washer
1-31	1006	Ruler
1-32	4096	Slide plate screws (6)
1-33	4097	Slide plate screws (2)
1-31	1003	Slide plate A
1-35	1004	Slide plate B
1-36	1005	Slide plate C
1-37	1563	Waste feeder screw
1-38	6254	Waste feeder stop pin
1-39	1562	Hex head slotted screws, base plate (2)
1-40	1002	Bed
1-41	1036	Belt cover plate
1-42	1036-40	Belt cover plate screw
1-43	1037	Belt cover lid
1-44	1038	Belt cover lid stopper
1-45	1009	Ruler set screw
1-46	2001	Hinges (2)
1-47	2002	Hinge pins (2)
1-48	2002-16	Hinge screw washers (4)
1-49	2002-30	Hinge screws (4)
1-50	1105	Waste feeder metals (set)

2. KNIFE AND RELATED PARTS

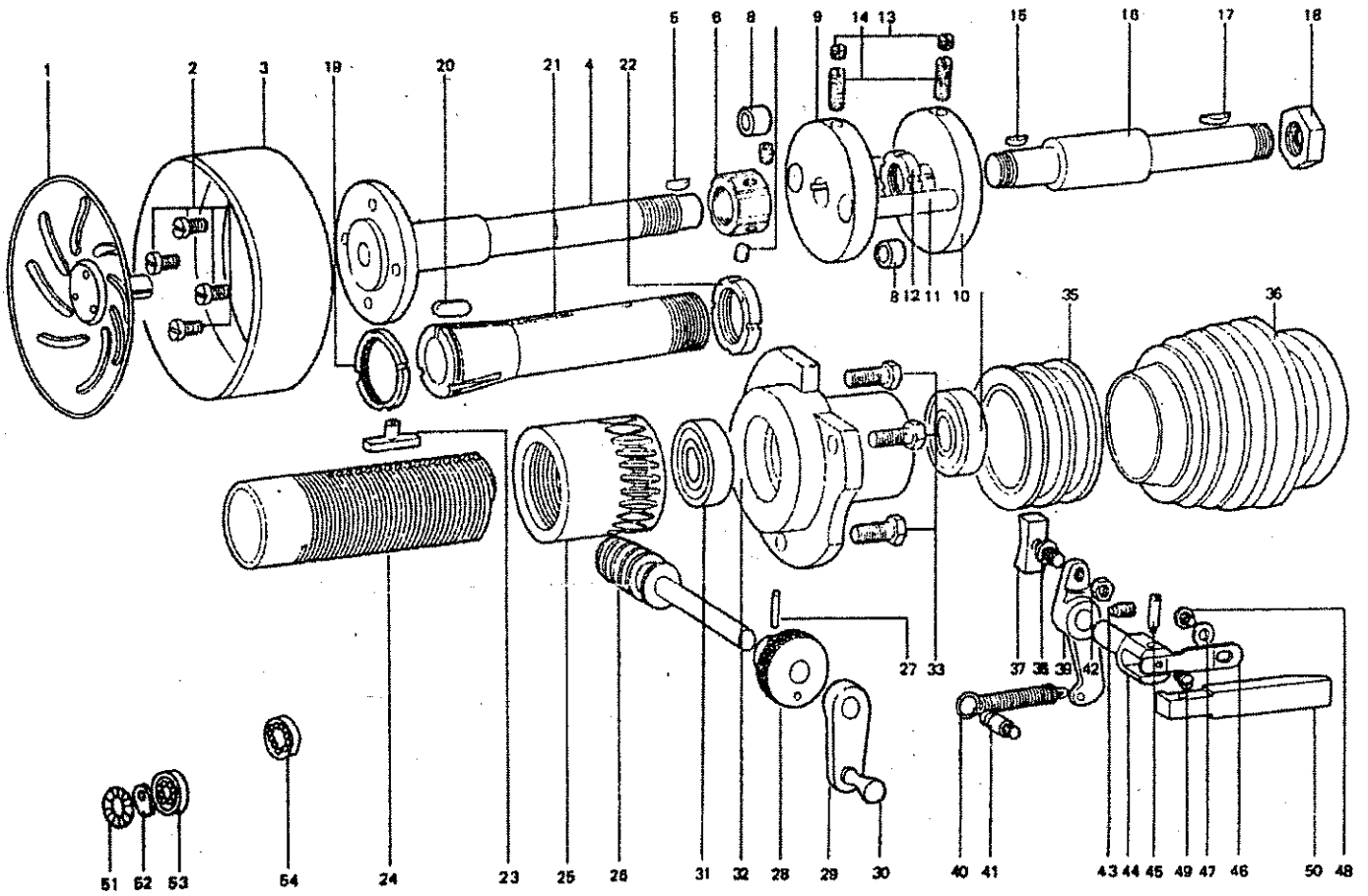

Item No.	Part No.	Description
2-1	1021	Leather peeler cover
2-2	1610	Knife set screws (4)
2-3	1010	Knife
2-4	1011	Knife shaft
2-5	3013	Knife shaft key
2-6	81875	Knife shaft nuts (2)
2-7		
2-8	1023	Rubber bushings (2)
2-9	1015	Pulley shaft flange holder
2-10	1033	Pulley shaft flange
2-11	1034	Flange shafts (2)
2-12	428x16x75	Pulley shaft flange nut
2-13	9/32x28x4.5	Pulley shaft flange screws (B) (2)
2-14	9/32x28x18	Pulley shaft flange screws (A) (2)
2-15	3x10	Pulley shaft key (small)
2-16	1031	Pulley shaft
2-17	3x16	Pulley shaft key (large)
2-18	M16 pXP1.5	Hexagonal nut (A)
2-23	1020	Knife shaft lead pipe key
2-24	1013	Knife shaft lead pipe
2-25	1014	Knife shaft worm wheel
2-26	1016	Knife shaft worm
2-27	3x18	Taper pin
2-28	1017	Knife adjusting knob
2-29	1018	Knife adjusting handle
2-30	1020	Knife adjusting handle knob
2-31	6203 Z	pulley shaft hearings
2-32		
2-33	5/16"x24x21	pulley shaft metal screws (3)
2-34		
2-35	1035	Clutch
2-36	1030	Pulley
2-37	1049	Clutch slide block
2-38	1040	Clutch slide block screws (3)
2-39	1043	Clutch arm
2-40	1024	Clutch spring
2-41	1046	Clutch spring hook
2-42	¼"x40	Clutch slide block screw nut
2-43	15/64x28x81	Clutch lever screw
2-44	1041	Clutch lever shaft
2-45	1160	Clutch arm server shaft
2-46	1042	Clutch lever spring
2-47		Clutch lever spring hinge washer
2-48	9/64"x40x6	Clutch lever spring hinge screw
2-49	9/64"x40x6	Clutch lever spring screw
2-50	1039	Clutch lever
2-51	NTB 2035	Truss bearing
2-52	20x35x1	Flat gasket
2-53	6004 ZZ	Bearing
2-54	6023 ZZ	Bearing

3. GRINDSTONE AND ROLLER RELATED PARTS

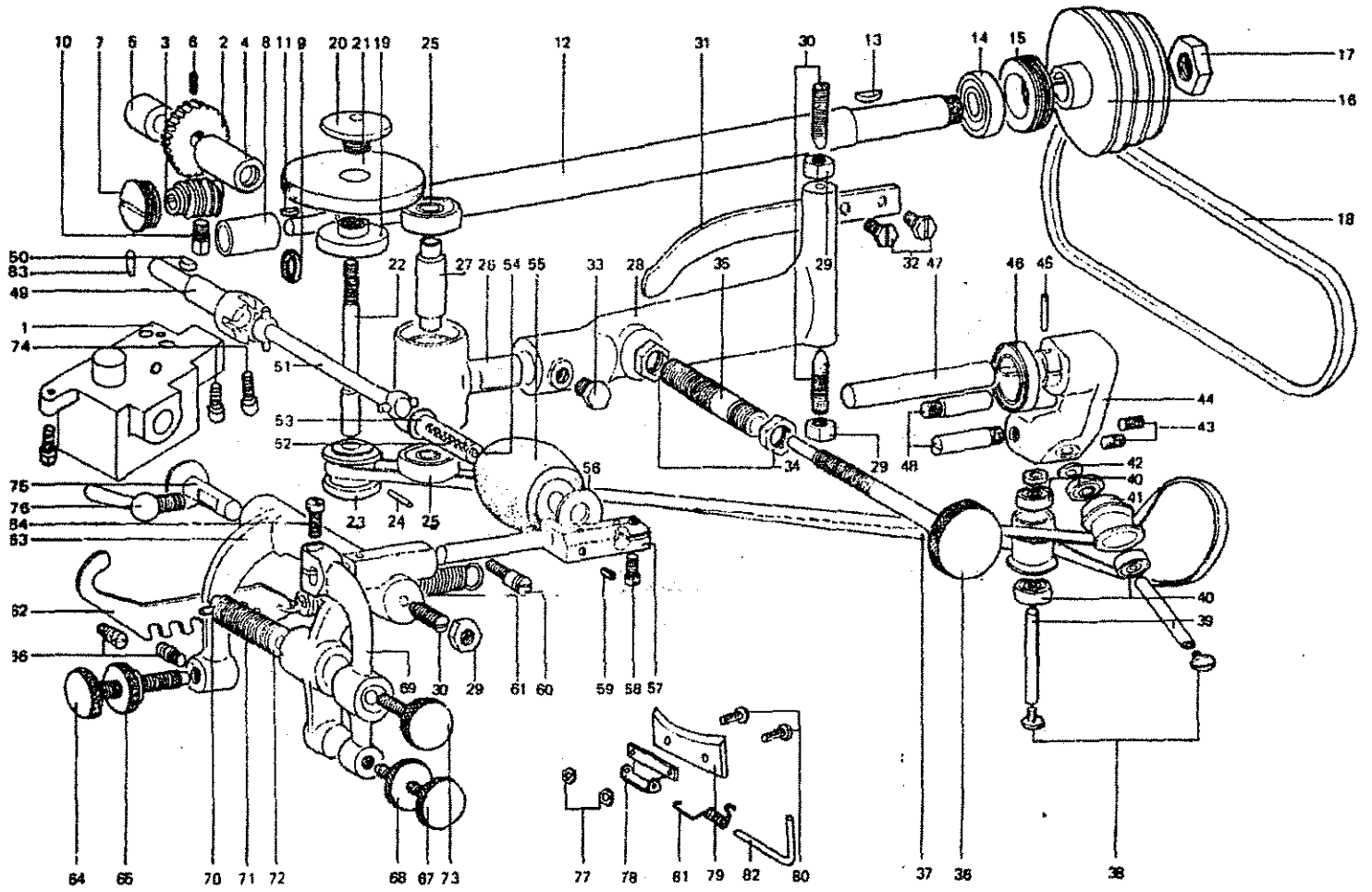

Item No.	Part No.	Description
3-1	1116	Worm wheel box
3-2	1115	Main shaft worm gear wheel
3-3	1119	Main shaft worm gear
3-4	1120	Roller driving shaft metal (1)
3-5	9/64"x40x90	Roller driving shaft metal (2)
3-6	1123	Main shaft worm gear wheel screw
3-7	1117	Main shaft worm gear chamber cover screw
3-8	121803	Main shaft front bushing
3-9	1123	Main shaft worm gear chamber oil seal
3-10	2.5x10	Main shaft worm gear chamber screw
3-11	1110	Main shaft key (1)
3-12	3x16	Main shaft
3-13	6002 ZZ	Main shaft key (2)
3-14	M63x 10P1.5	Main shaft bearing
3-15	1111	Main shaft bearing holder screw
3-16	M14xP1.5	Main shaft pulley
3-17	3 starK20	Hexagonal nut B
3-18	1051	Main shaft belt
3-19	1052	Grindstone set screw
3-20	1050	Grindstone set screw nut
3-21	1053	Grindstone
3-22	2.5x20	Grindstone shaft
3-24	6200 Z	Grindstone shaft pulley taper pin
3-25	1056	Grindstone shaft bearings (2)
3-27	1055	Grindstone shaft bracket
3-28	1057	Grindstone shaft bearing roller
3-29	5/16x24	Grindstone shaft bracket arm
3-30	1731	Grindstone shaft bracket arm center screw nuts
3-31	1069	Grindstone shaft bracket arm center screws
3-32	15/64x24x14	Grindstone shaft bracket arm spring
3-33	5/16x24x14	Grindstone shaft bracket arm spring screws
3-34	½"x28	Grindstone adjusting screw pipe nuts (2)
3-35	1066	Grindstone adjusting screw pipe
3-36	1058	Grindstone adjusting screw
3-37	1059	Grindstone shaft belt
3-38		
3-39	1063	Belt guide pulley screws (2)
3-40	626 Z	Belt guide pulley shafts (2)
		Belt guide pulley bearings (4)
3-41	1062	Belt guide pulleys (2)
3-42	1063	Belt guide pulley washers (2)

Item No.	Part No.	Description
3-43	15/64x28x8	Belt guide pulley shaft screws (2)
3-44	1060	Belt guide bracket
3-45	3x18	Belt guide bracket taper pin
3-46	1067	Belt guide bracket spring
3-47	1061	Belt guide bracket shaft
3-48	1065	Belt guide bracket turn stoppers
3-49	1118	Roller driving shaft
3-50	3x13	Roller driving shaft key
3-51	1121	Roller driving shaft joint
3-52	1094	Roller shaft oil wick
3-53	1081	Roller shaft
3-54		Roller shaft oil scalping
3-55	1080	Roller
3-56	1082	Roller washer
3-57	1083	Roller bracket
3-58	15/64x28x10	Roller shaft screw
3-59	11/64x40x3.5	Waste clear metal shaft screw
3-60	1098	Roller bracket arm spring hooks (2)
3-61	1095	Roller bracket arm spring
3-62	1096	Roller bracket arm spring hook metal
3-63	1091	Roller bracket arm
3-64	1092	Roller bracket arm adjusting screw
3-65	1093	Roller bracket arm adjusting screw nut
3-66	1097	Roller bracket arm spring hooks (2)
3-67	1085	Roller bracket turning arm adjusting screw
3-68	1086	Roller bracket turning arm adjusting screw nut
3-69	1083	Roller bracket turning arm
3-70	1088	Roller bracket turning arm spring stopper
3-71	1087	Roller bracket turning arm spring
3-72	1090	Roller bracket turning arm spring adjusting nut
3-73	1089	Roller bracket turning arm spring adjusting nut screw
3-74	1/4x20x20	Set screw (3)
3-75	1099	Roller bracket arm center pin
3-76	1100	Roller bracket arm center pin screw
3-77	9/64x10	Waste clear metal leather nuts (2)
3-78	1101	Waste clear metal
3-79	1104	Waste clear metal leather
3-80	9/64x40	Waste clear metal leather screws (2)
3-81	1103	Waste clear metal spring
3-82	1102	Waste clear metal shaft
3-83	4x22	Taper pin
3-84		Roller shaft screw

4. ACCESSORIES

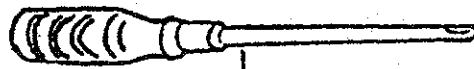
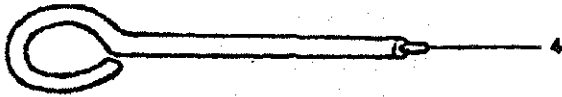
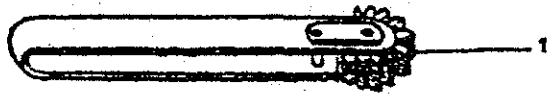

7

6



A 40m/m
B 30m/m
C 25m/m

Item No.	Part No.	Description
3-1	3001	Grindstone dresser
4-2	3002	Grindstone spanner
3-3	3004	Knife shaft spanner
4-4	3005	Knife interior cover remover
4-5	3006	Bar type grindstone
4-6	3007	Screwdriver (large)
4-7	3008	Oiler
1-16 A	1130 A	Presser foot 50 mm
1-16 B	1140 B	Presser foot 30 mm
1-16C	1140 C	Presser foot 25 mm
1-47	2002	Hinge pins (2)
1-36	2001	Hinges (2)
1-48	15x6.3x1.6	Hinge set screw washers (2)
1-39	6x30	Hinge set screws (4)
2-29	1018	Knife adjusting handle
2-30	1019	Knife adjusting handle
4-5	3006	Bar type grindstone